

AT-250 AL-TRACK

Corrugated Aluminum Insert

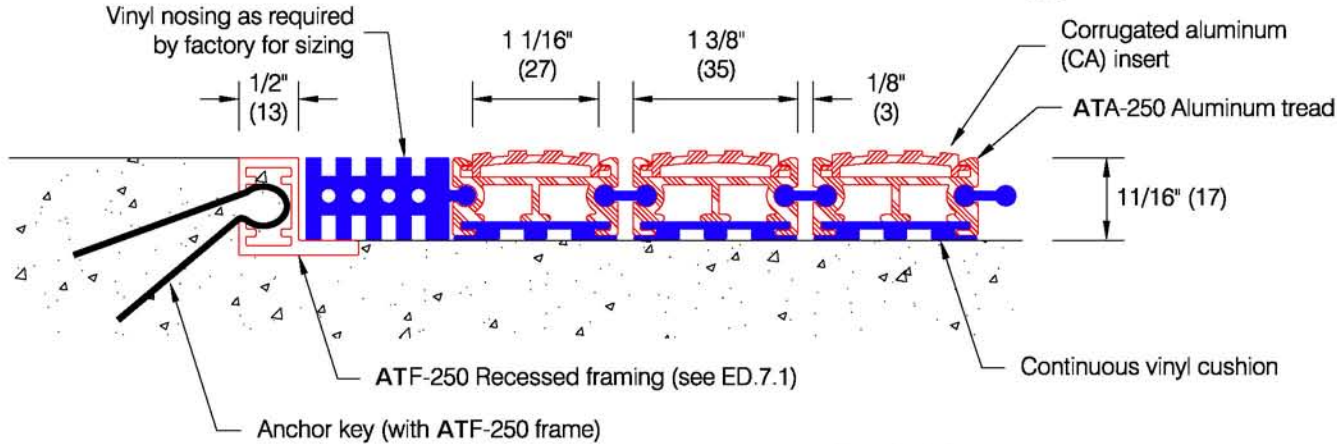

Features:

- Extruded aluminum treads alloy 6105-T5
- Continuous vinyl cushion for superior noise reduction
- 3/4" (19) deep for increased drainage ability
- Perforated hinge for added drainage
- Single section width to 144" (3568)
- Static Coefficient of Friction (ASTM D-2047-82)
Dry: 0.61, Wet: 0.92

Finishes:

- Aluminum tread:
 - Mill finish (standard) #405
 - Medium bronze anodized #404
 - Clear anodized #403
 - Black anodized #462
- Corrugated aluminum insert alloy 6105-T5:
 - Mill finish (standard) #405

Optional Framing:

* Amarco requires that exact mat opening dimensions be provided. Factory will fabricate mats 1/4" (6) smaller than exact opening dimensions to allow for proper fit.

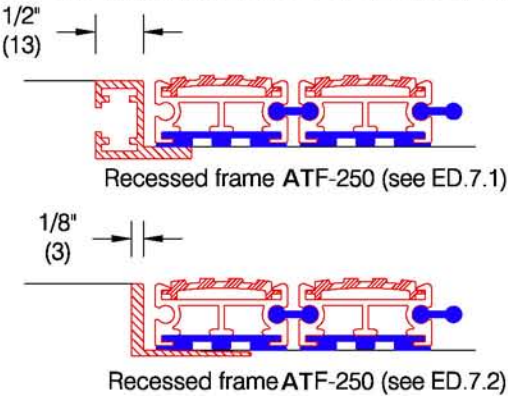

Hinge Detail:

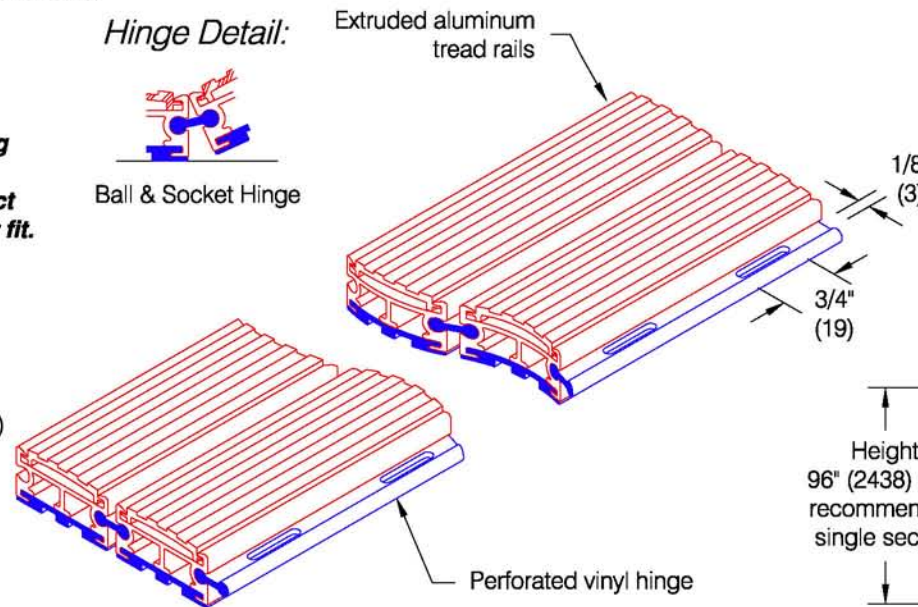

Sectioning information:

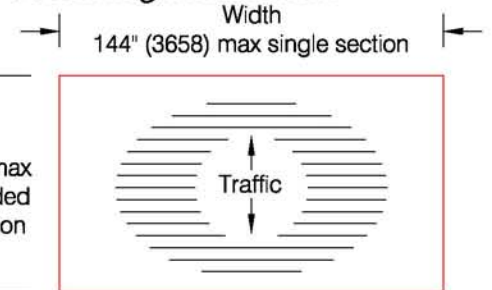

* Mats over 48 square feet may require sectioning as determined by the factory

Amarco reserves the right to discontinue a design or modify an existing design without prior notice

Customer :	Project :	ED.35.3a
Architect :	Sales Rep :	