

G-1532 - 15/32" Buffed Tire Grating

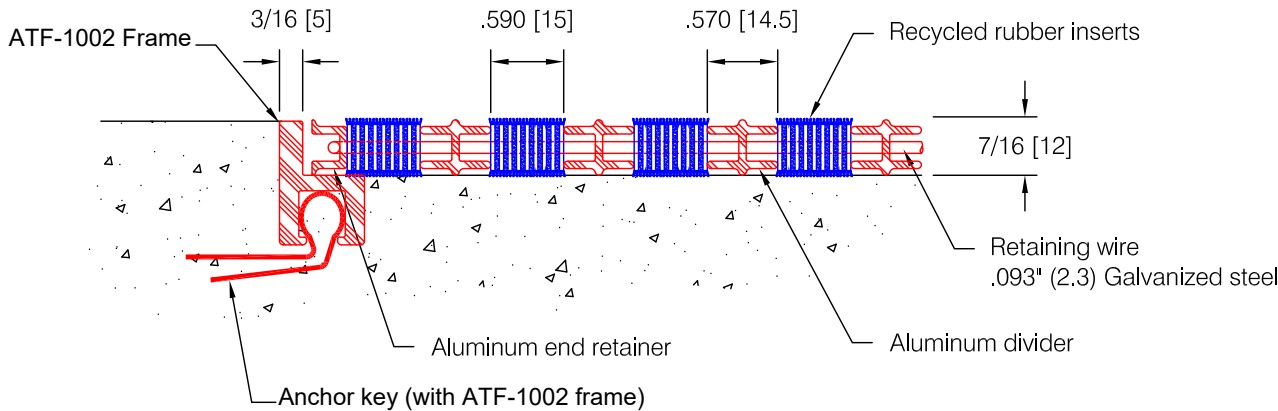

*** Note On Dimensions:**

Amarco Products requires that exact opening dimensions be provided. Factory will fabricate mats 1/4" (6) smaller than exact opening dimensions to allow for proper fit on dimensions without nosing.

Nylon fiber surface exposed by "buffing" to remove .040" (1) rubber

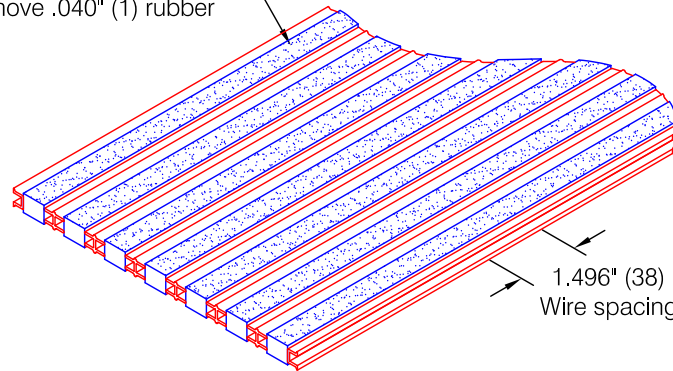

"CS" : Closed Construction, Single Insert

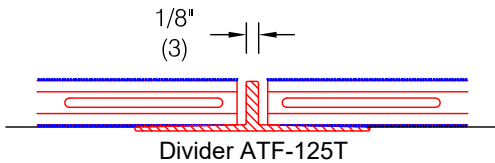
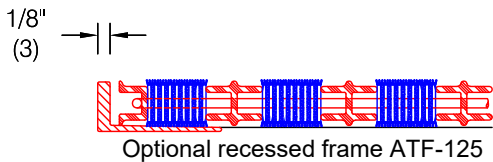

Features:

- Inserts:
Recycled content 100% post-consumer
- Reversible for extended life
- Weight: 2.6 lbs/sqft

Finishes:

- Aluminum profiles:
Mill finish (standard) #405
Clear anodized #403
- Insert: Natural Gray #17
- Wire: Cold galvanized, 30-35 micron

Construction:

- Closed construction and single insert. Dirt and debris remain on surface for cleaning
- Manufacturing process prevents exact alignment of aluminum profiles and rubber inserts between adjacent sections

Sectioning information:

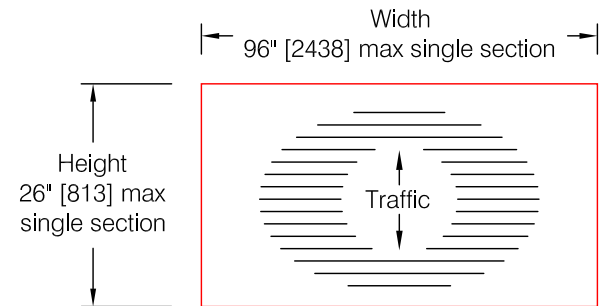

*** Mats over 16 square feet may require sectioning as determined by the factory**

Customer :

Project :

Architect :

Sales Rep :

G-1532 - 15/32" Buffed Tire Grating

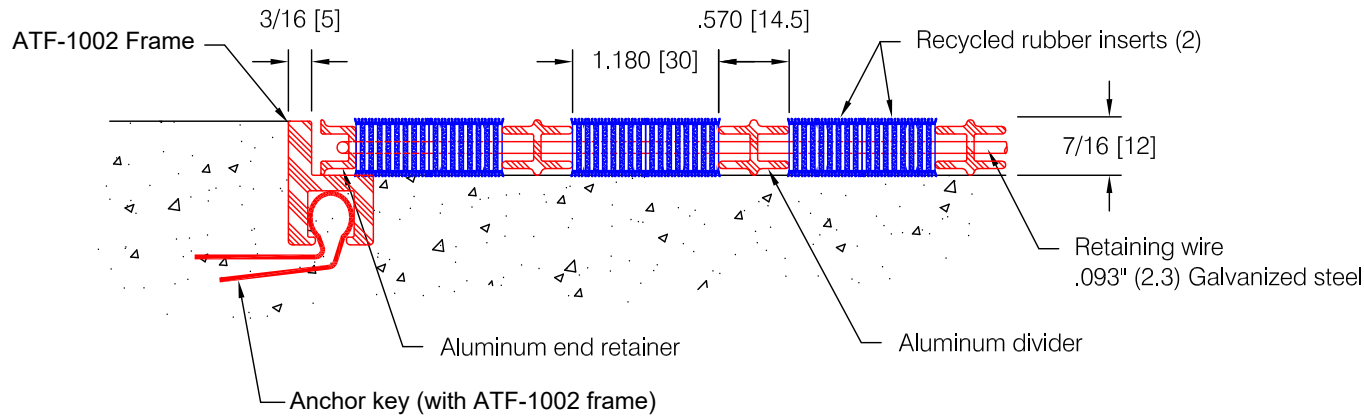

*** Note On Dimensions:**

Amarco Products requires that exact opening dimensions be provided. Factory will fabricate mats 1/4" (6) smaller than exact opening dimensions to allow for proper fit on dimensions without nosing.

Nylon fiber surface exposed by "buffing" to remove .040" (1) rubber

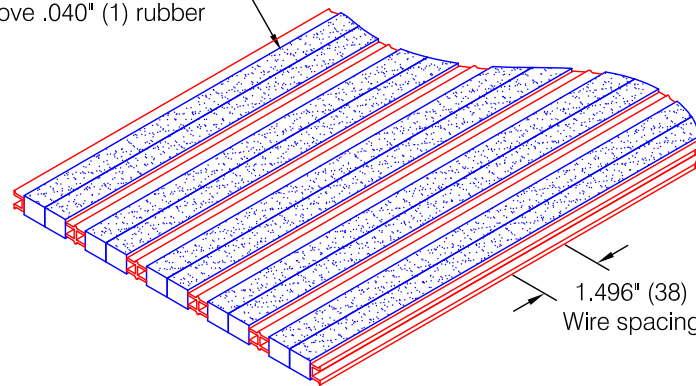

"CD" : Closed Construction, Double Insert

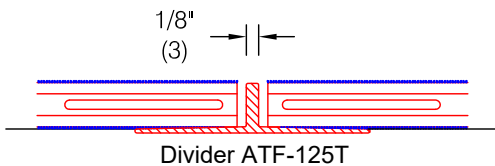
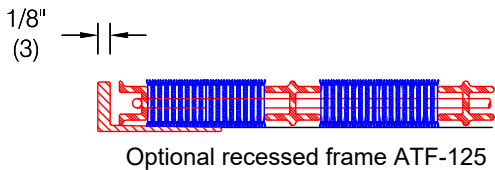

Features:

- Inserts:
Recycled content 100% post-consumer
- Reversible for extended life
- Weight: 2.66 lbs/sqft

Finishes:

- Aluminum profiles:
Mill finish (standard) #405
Clear anodized #403
- Insert: Natural Gray #17
- Wire: Cold galvanized, 30-35 micron

Construction:

- Closed construction and double insert. Dirt and debris remain on surface for cleaning
- Manufacturing process prevents exact alignment of aluminum profiles and rubber inserts between adjacent sections

Sectioning information:

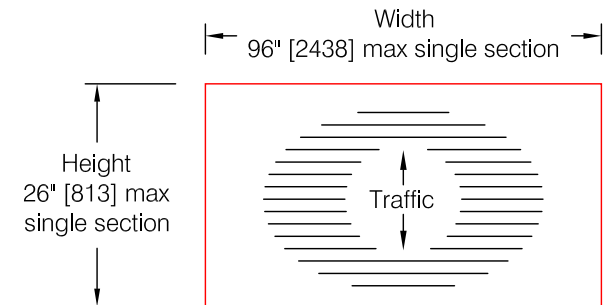

*** Mats over 16 square feet may require sectioning as determined by the factory**

Amarco Products reserves the right to discontinue a design or modify an existing design without prior notice

Customer :

Project :

Architect :

Sales Rep :