

G-300 - 1.5" Aluminum Foot Grille w/ Nylon Carpet Insert

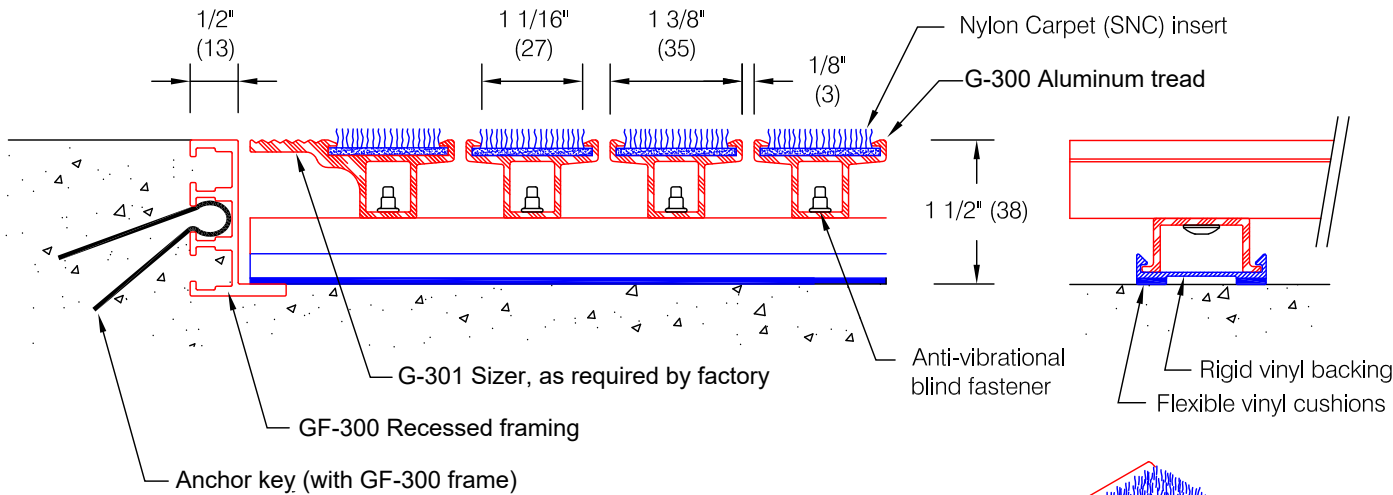

Note On Dimensions:

* Amarco Products requires that exact opening dimensions be provided. Factory will fabricate mats 1/4" (6) smaller than exact opening dimensions to allow for proper fit on dimensions without nosing.

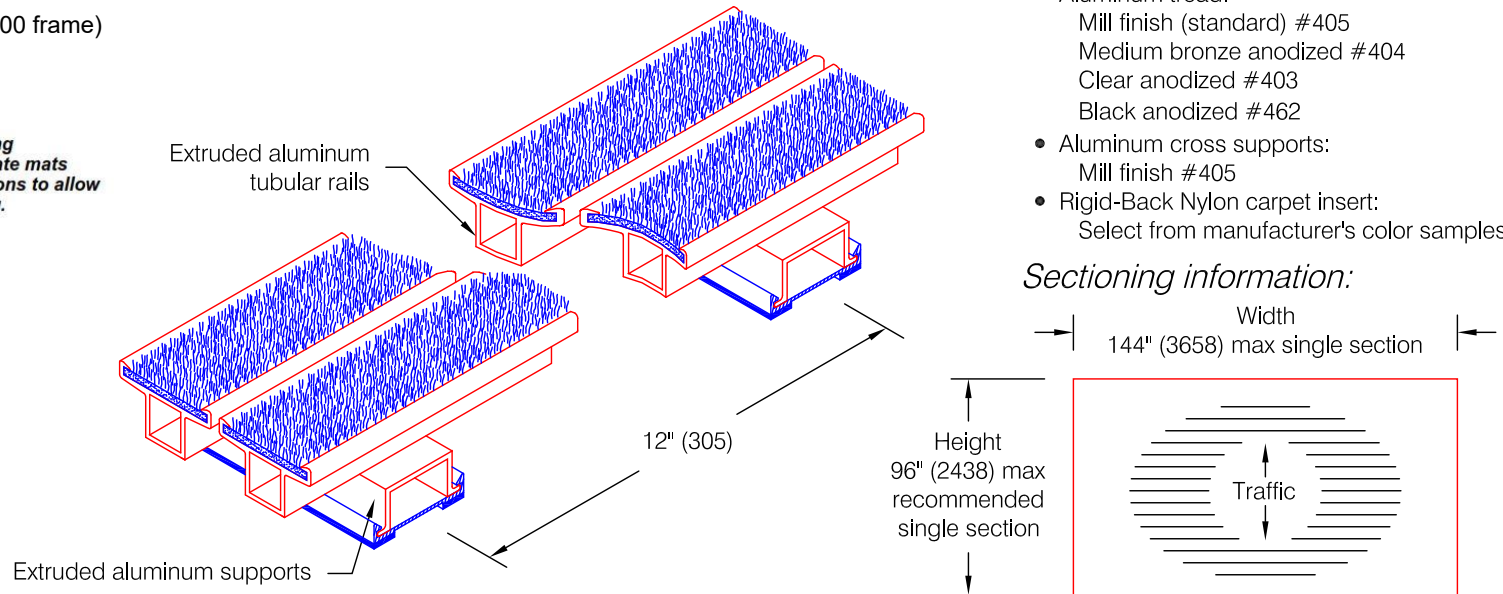
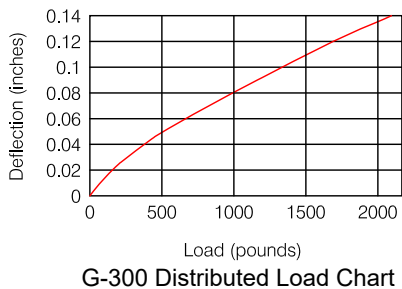

Features:

- Extruded aluminum treads and cross supports alloy 6105-T5
- Continuous dual-durometer vinyl cushion for superior noise reduction
- 1 1/2" (38) deep for increased drainage ability
- Tubular tread rails for increased strength
- Anti-vibrational fasteners for sturdy, long-life service
- Single section width to 144" (3658)
- 100% solution dyed nylon fiber with 1/4" (6) finish pile height, 33.8 oz/sq yd in rigid backing
- Static Coefficient of Friction (ASTM D-2047-82)
Dry: 0.48, Wet: 0.67

Finishes:

- Aluminum tread:
 - Mill finish (standard) #405
 - Medium bronze anodized #404
 - Clear anodized #403
 - Black anodized #462
- Aluminum cross supports:
 - Mill finish #405
- Rigid-Back Nylon carpet insert:
 - Select from manufacturer's color samples

Sectioning information:

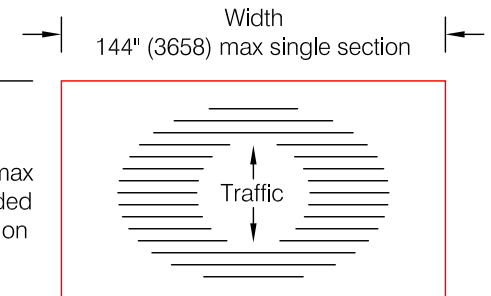

* Mats over 48 square feet may require sectioning as determined by the factory

Amarco Products reserves the right to discontinue a design or modify an existing design without prior notice

Customer :	Project :	
Architect :	Sales Rep :	

G-300 - 1.5" Aluminum Foot Grille w/ Aluminum Abrasive Insert

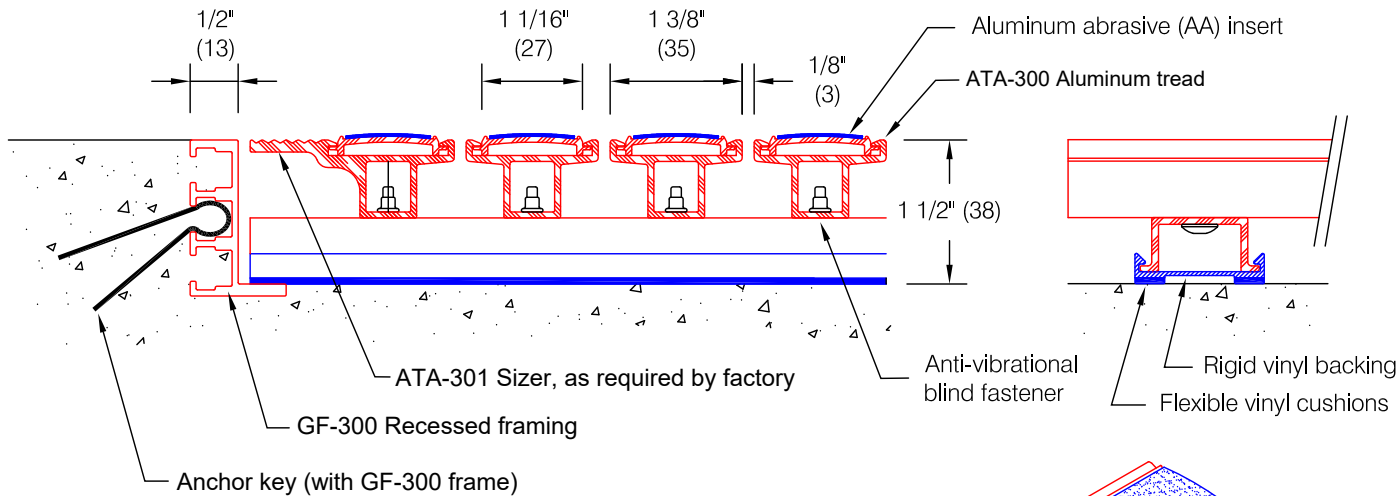

Note On Dimensions:

* Amarco Products requires that exact opening dimensions be provided. Factory will fabricate mats 1/4" (6) smaller than exact opening dimensions to allow for proper fit on dimensions without nosing.

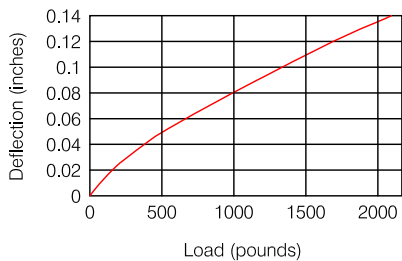

G-300 Distributed Load Chart

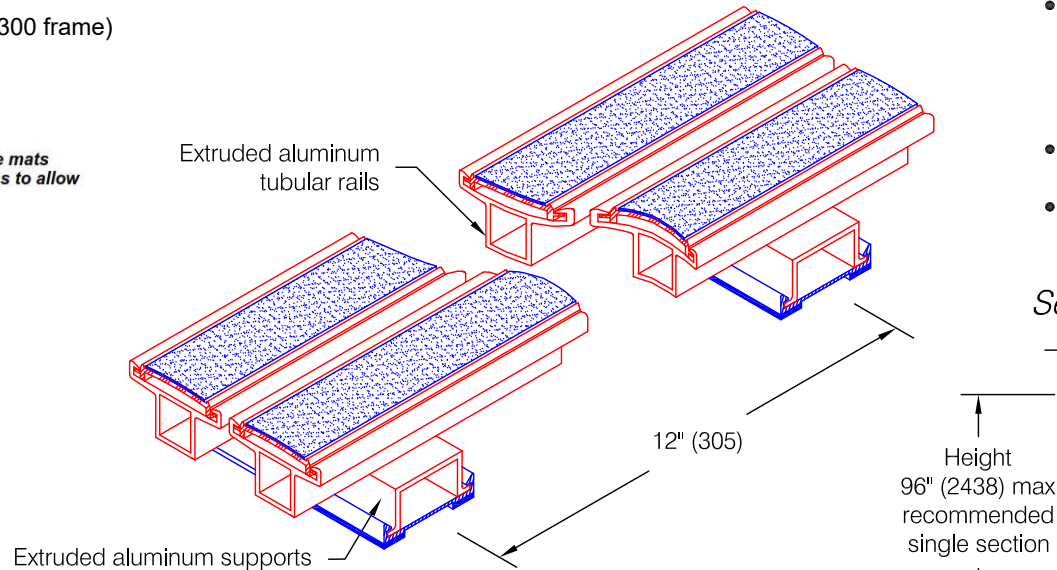

Features:

- Extruded aluminum treads and cross supports alloy 6105-T5
- Continuous dual-durometer vinyl cushion for superior noise reduction
- 1 1/2" (38) deep for increased drainage ability
- Tubular tread rails for increased strength
- Anti-vibrational fasteners for sturdy, long-life service
- Single section width to 144" (3568)
- Aluminum abrasive insert: Extruded aluminum base with applied abrasive strip
- Static Coefficient of Friction (ASTM D-2047-82)
Dry: > 1.14, Wet: > 1.20

Finishes:

- Aluminum tread:
 - Mill finish (standard) #405
 - Medium bronze anodized #404
 - Clear anodized #403
 - Black anodized #462
- Aluminum cross supports:
 - Mill finish #405
- Aluminum abrasive insert alloy 6105-T5:
 - Mill finish aluminum base (standard) #405
 - Abrasive from manufacturer's color samples

Sectioning information:

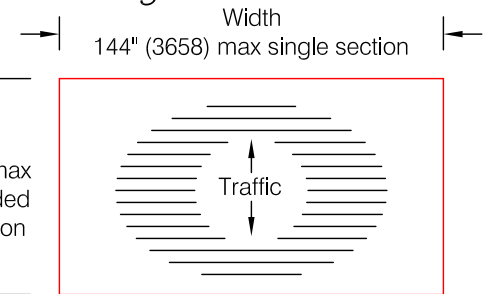

* Mats over 48 square feet may require sectioning as determined by the factory

Amarco Products reserves the right to discontinue a design or modify an existing design without prior notice

Customer :	Project :
Architect :	Sales Rep :

G-300 - 1.5" Aluminum Foot Grille w/ Bristle Filament Carpet Insert

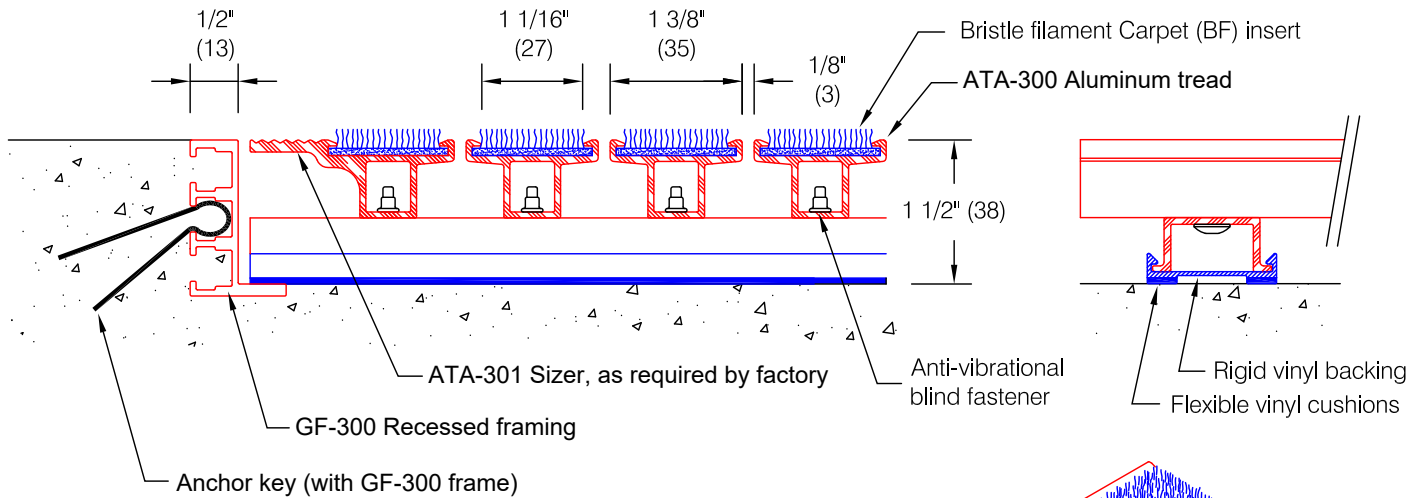

Features:

- Extruded aluminum treads and cross supports alloy 6105-T5
- Continuous dual-durometer vinyl cushion for superior noise reduction
- 1 1/2" (38) deep for increased drainage ability
- Tubular tread rails for increased strength
- Anti-vibrational fasteners for long-life service
- Single section width to 144" (3658)
- Solution dyed polypropylene fibers, 27 oz/sqyd with 50% Blend 600/12-Denier multi-filament and 595/D1 monofilament. Fibers are fusion bonded to continuous two-ply rigid backing.
- Fibers are waterproof with UV inhibitors
- Static Coefficient of Friction (ASTM D2047) Dry: 0.64, Wet: 0.67

Finishes:

- Aluminum tread:
 - Mill finish (standard) #405
 - Medium bronze anodized #404
 - Clear anodized #403
 - Black anodized #462
- Aluminum cross supports: Mill finish #405
- Bristle filament carpet insert:
 - Manufacturer's standard colors

Sectioning information:

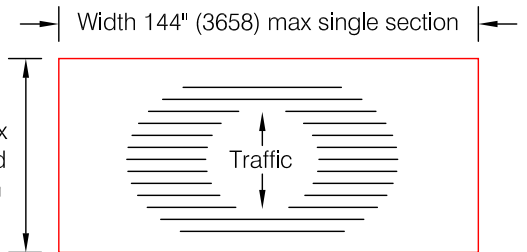

* Mats over 48 square feet may require sectioning as determined by the factory

Note On Dimensions:

* Amarco Products requires that exact opening dimensions be provided. Factory will fabricate mats 1/4" (6) smaller than exact opening dimensions to allow for proper fit on dimensions without nosing.

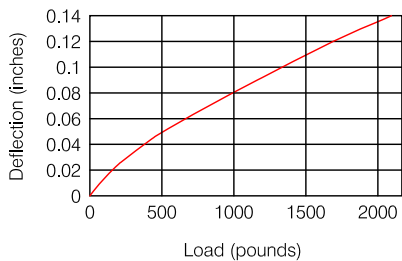

G-300 Distributed Load Chart

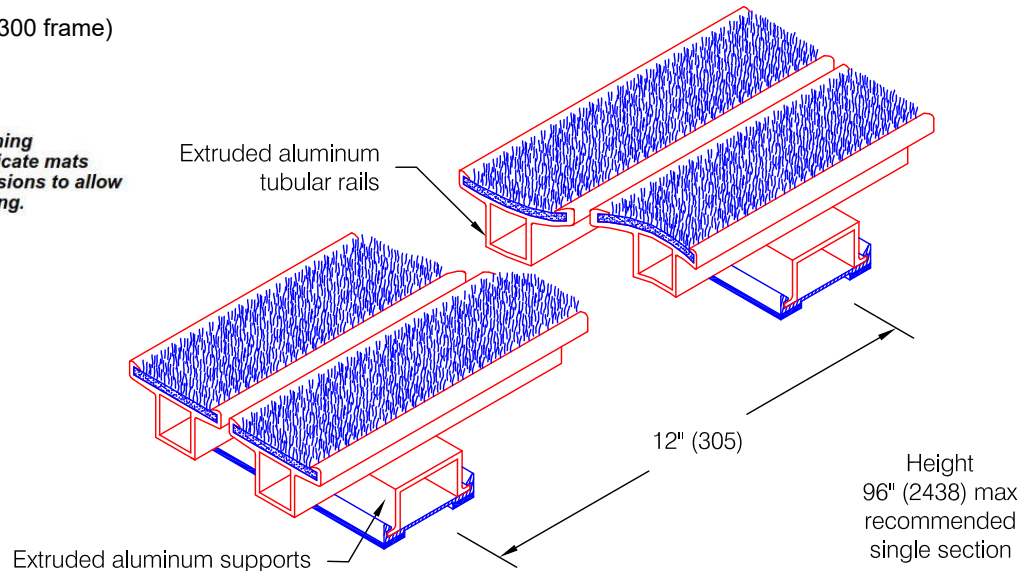

Amarco Products reserves the right to discontinue a design or modify an existing design without prior notice

Customer :	Project :
Architect :	Sales Rep :

G-300 - 1.5" Aluminum Foot Grille w/ Maxi-Tuft Insert

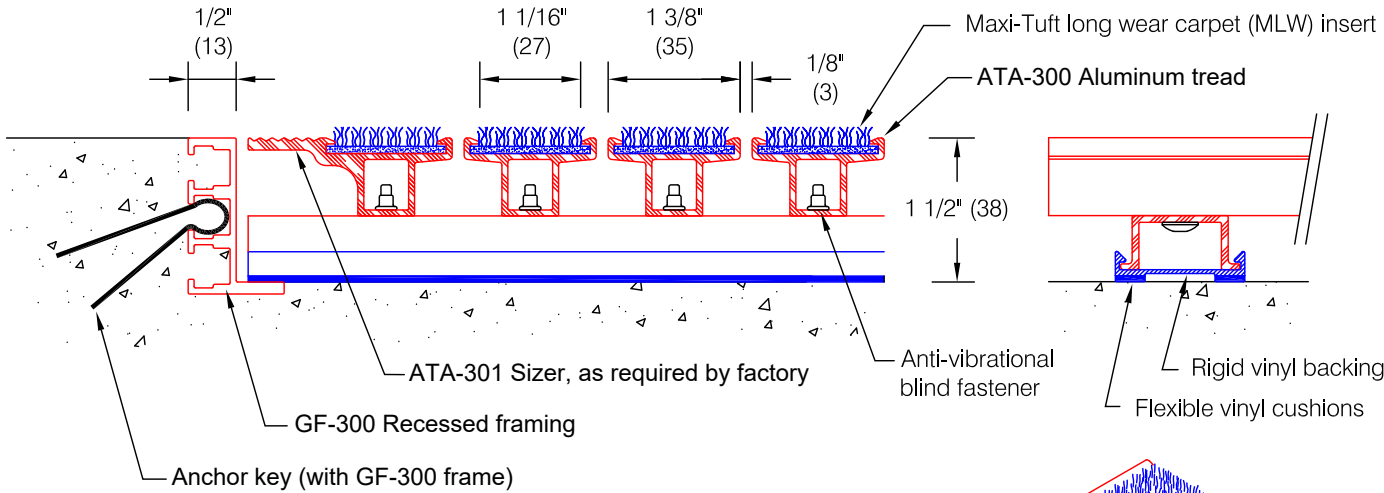

Features:

- Extruded aluminum treads and cross supports alloy 6105-T5
- Continuous dual-durometer vinyl cushion for superior noise reduction
- 1 1/2" (38) deep for increased drainage ability
- Tubular tread rails for increased strength
- Anti-vibrational fasteners for sturdy, long-life service
- Single section width to 144" (3568)
- Space dyed, 100% polyamide nylon, tetra-lobal fibers, 5/32 (4) pile height, 30 oz/sq yd
- Static Coefficient of Friction (ASTM D-2047-82)
Dry: 0.49, Wet: 0.77

Finishes:

- Aluminum tread:
 - Mill finish (standard) #405
 - Medium bronze anodized #404
 - Clear anodized #403
 - Black anodized #462
- Aluminum cross supports:
 - Mill finish #405
- Maxi-Tuft long wear carpet insert:
 - Select from manufacturer's color samples

Sectioning information:

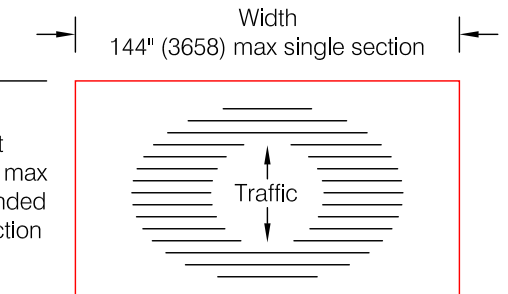

Note On Dimensions:

* Amarco Products requires that exact opening dimensions be provided. Factory will fabricate mats 1/4" (6) smaller than exact opening dimensions to allow for proper fit on dimensions without nosing.

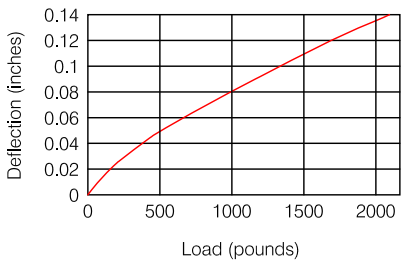

G-300 Distributed Load Chart

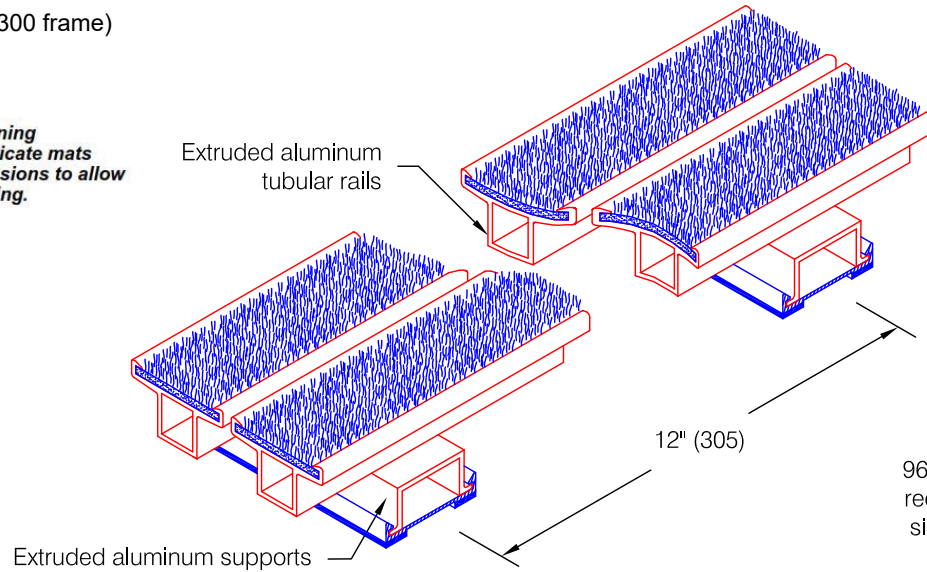

Amarco Products reserves the right to discontinue a design or modify an existing design without prior notice

* Mats over 48 square feet may require sectioning as determined by the factory

Customer :	Project :	
Architect :	Sales Rep :	

G-300 - 1.5" Aluminum Foot Grille w/ Corrugated Aluminum Insert

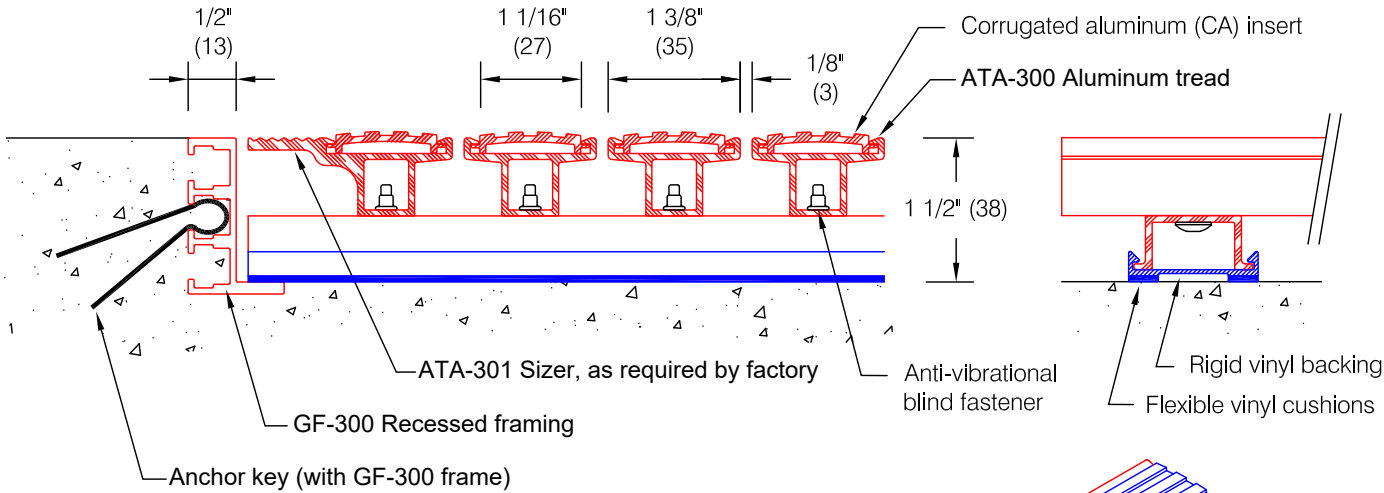

Features:

- Extruded aluminum treads and cross supports alloy 6105-T5
- Continuous dual-durometer vinyl cushion for superior noise reduction
- 1 1/2" (38) deep for increased drainage ability
- Tubular tread rails for increased strength
- Anti-vibrational fasteners for sturdy, long-life service
- Single section width to 144" (3568)
- Static Coefficient of Friction (ASTM D-2047-82)
Dry: 0.61, Wet: 0.92

Finishes:

- Aluminum tread:
 - Mill finish (standard) #405
 - Medium bronze anodized #404
 - Clear anodized #403
 - Black anodized #462
- Aluminum cross supports:
 - Mill finish #405
- Corrugated aluminum insert alloy 6105-T5:
 - Mill finish (standard) #405

Note On Dimensions:

* Amarco Products requires that exact opening dimensions be provided. Factory will fabricate mats 1/4" (6) smaller than exact opening dimensions to allow for proper fit on dimensions without nosing.

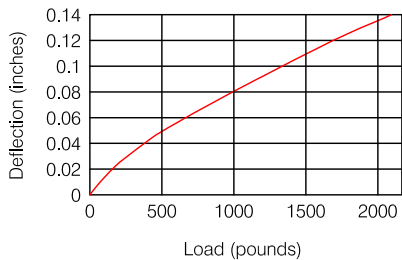

G-300 Distributed Rolling Load

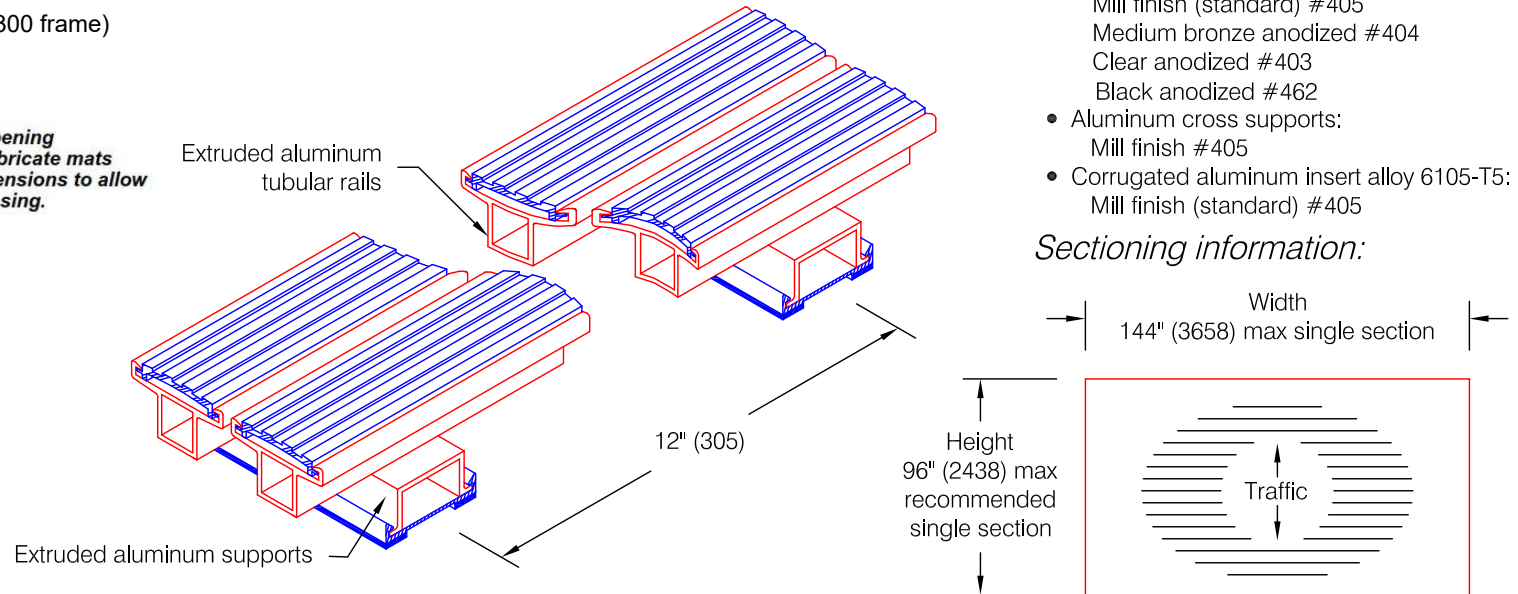

Sectioning information:

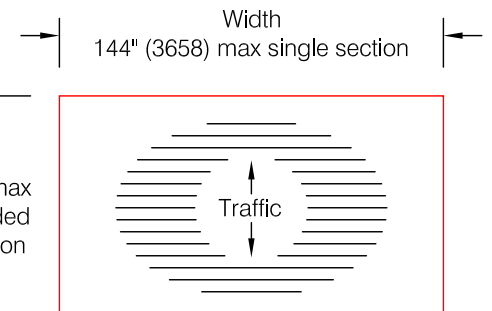

* Mats over 48 square feet may require sectioning as determined by the factory

Customer :	Project :	
Architect :	Sales Rep :	

G-300 - 1.5" Aluminum Foot Grille w/ Rigid Corrugated Vinyl Insert

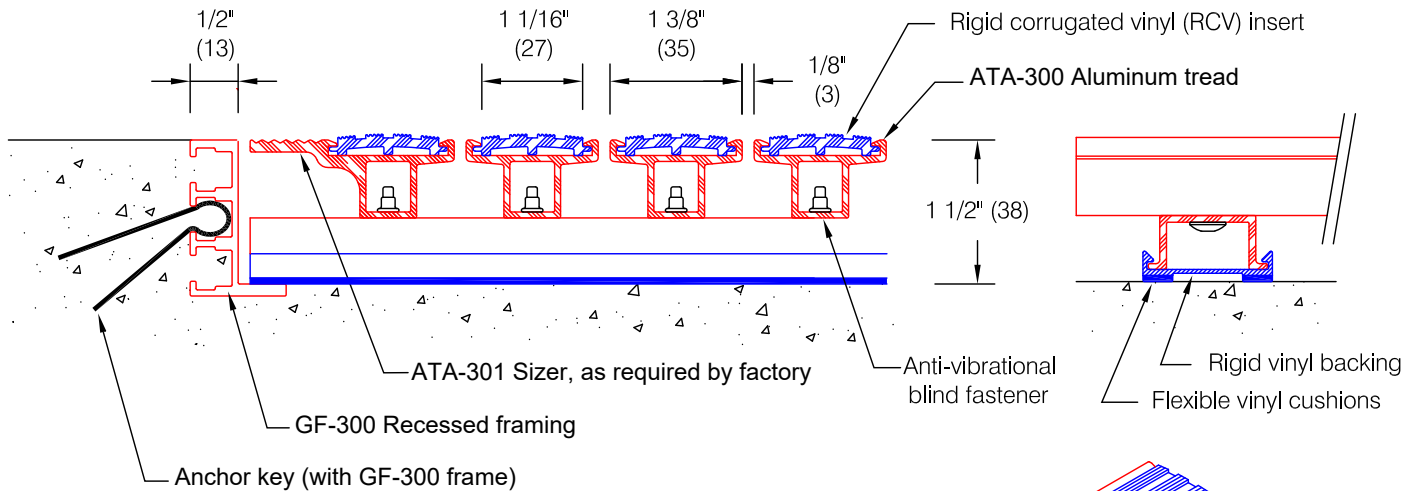

Features:

- Extruded aluminum treads and cross supports alloy 6105-T5
- Continuous dual-durometer vinyl cushion for superior noise reduction
- 1 1/2" (38) deep for increased drainage ability
- Tubular tread rails for increased strength
- Anti-vibrational fasteners for sturdy, long-life service
- Single section width to 144" (3568)
- Rigid corrugated vinyl insert (colorable)

Finishes:

- Aluminum tread:
 - Mill finish (standard) #405
 - Medium bronze anodized #404
 - Clear anodized #403
 - Black anodized #462
- Aluminum cross supports:
 - Mill finish #405
- Rigid corrugated vinyl insert (colorable):
 - Select from manufacturer's color samples

Note On Dimensions:

* Amarco Products requires that exact opening dimensions be provided. Factory will fabricate mats 1/4" (6) smaller than exact opening dimensions to allow for proper fit on dimensions without nosing.

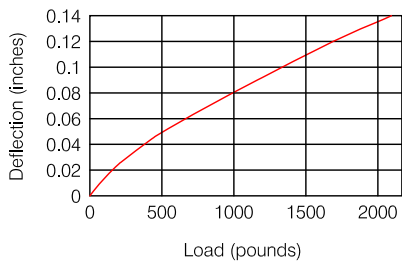

G-300 Distributed Load Chart

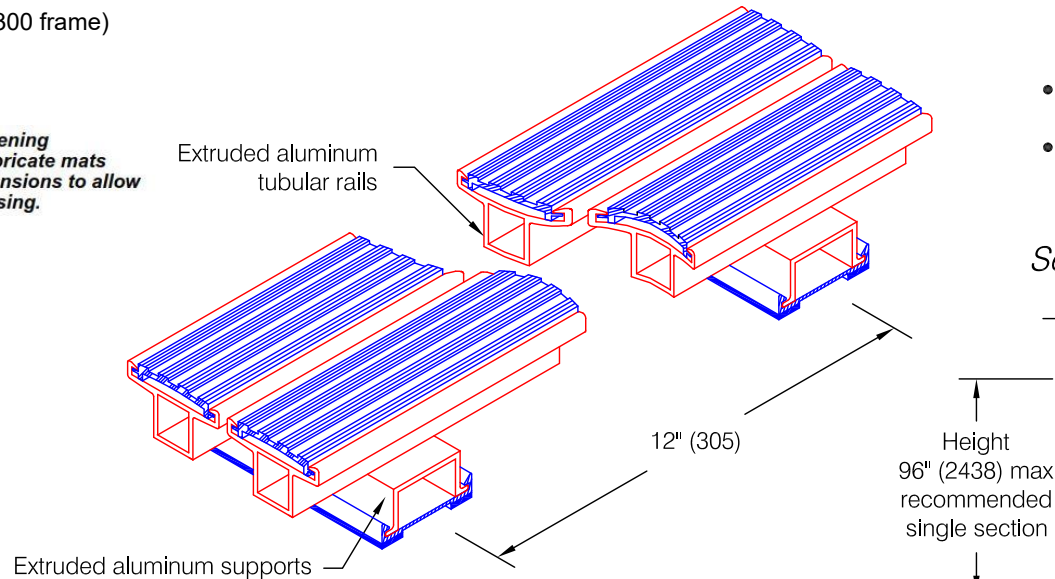

Sectioning information:



* Mats over 48 square feet may require sectioning as determined by the factory

Amarco Products reserves the right to discontinue a design or modify an existing design without prior notice

Customer :	Project :	
Architect :	Sales Rep :	

GF-300 Aluminum Recessed Frame

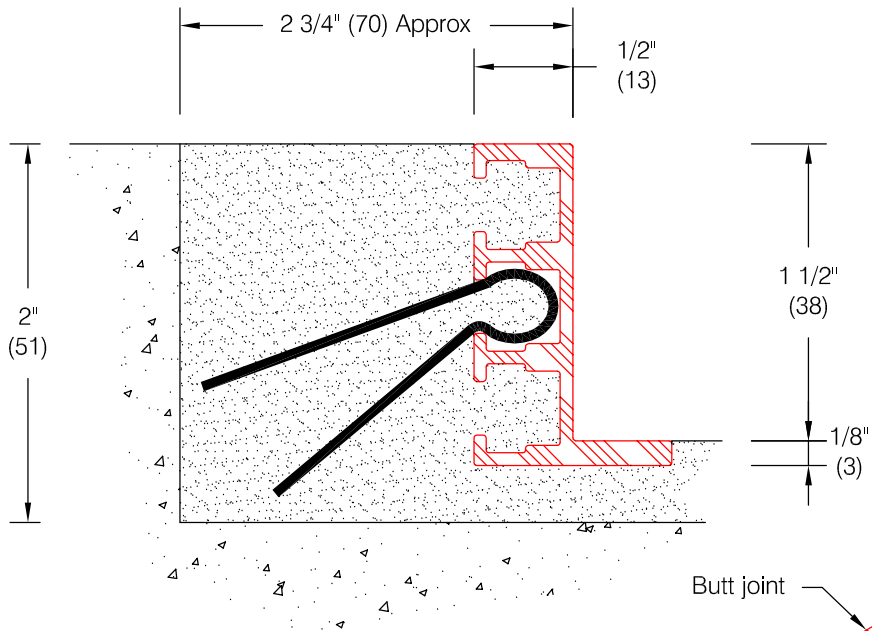

Features:

- Use with G-300 and G-400 gratings
- Extruded aluminum alloy 6063-T5
- Stock length: 12'-0" (3658)
- Weight: 0.45 lbs / lf

Installation Options:

- Recessed, cast in place

Standard Finishes:

- Mill Finish #405
- Clear anodized #403
- Medium bronze anodized #404
- Black anodized #462

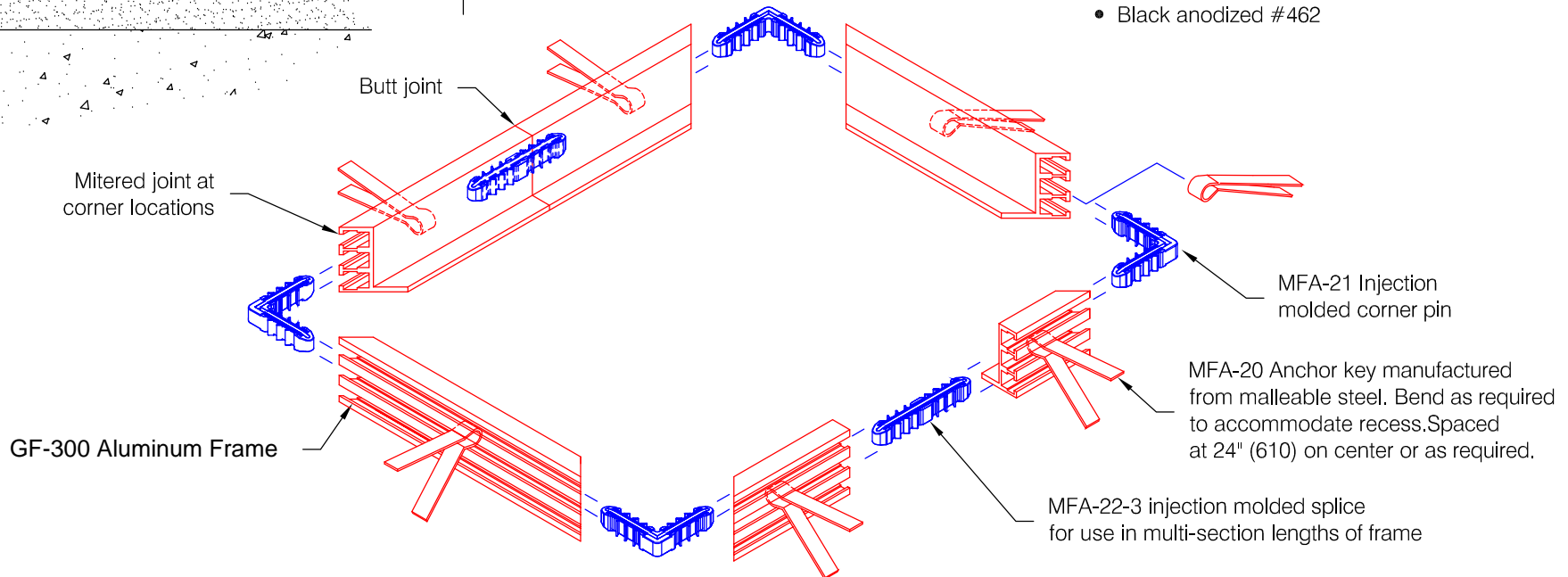

Amarco Products reserves the right to discontinue a design or modify an existing design without prior notice

Customer :

Project :

Architect :

Sales Rep :

ED.5.0c