

G-550R

QTY.	MODEL	WIDTH	LENGTH	LOCATION

RECESS OPENING DIMENSIONS:

120.000 WIDTH X 120.000 LENGTH

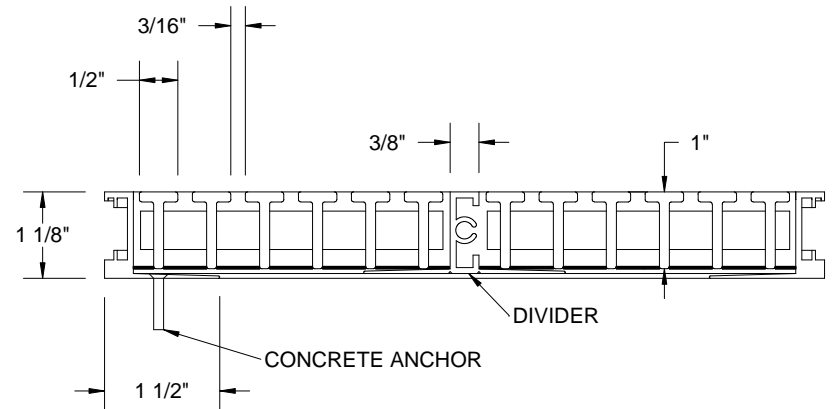
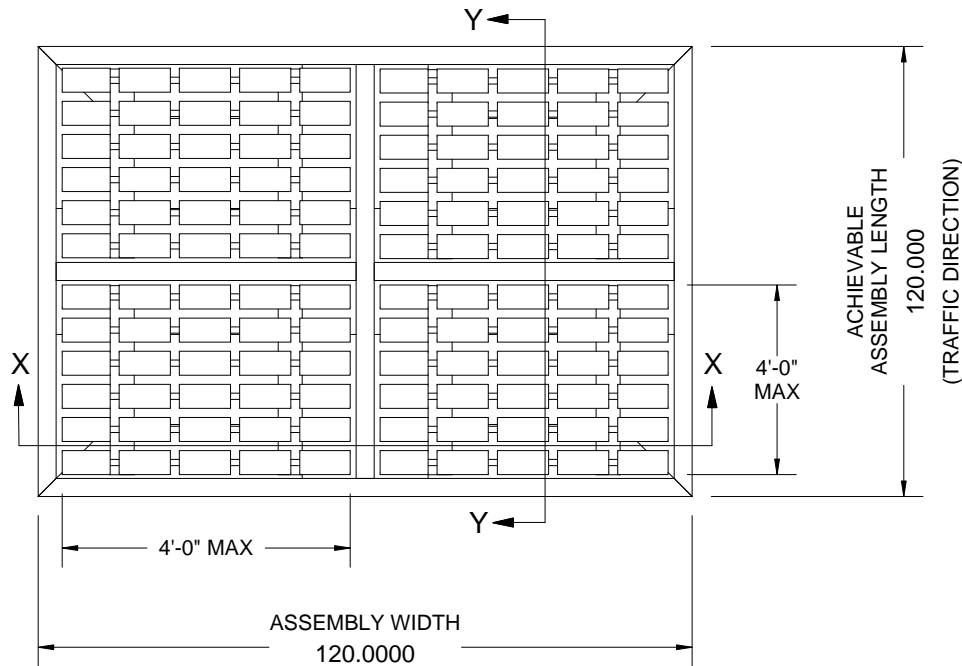

SECTION Y-Y

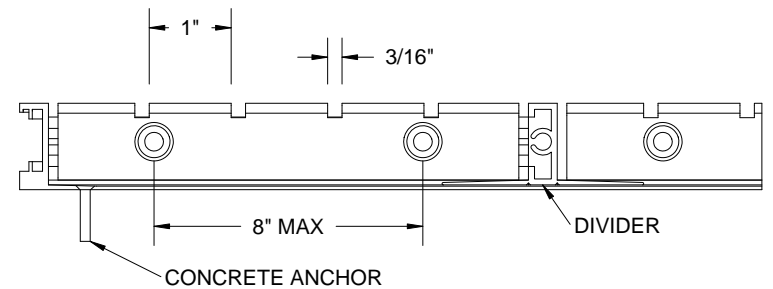

SECTION X-X

NOTES:

- MAXIMUM GRATE SECTION SIZE NOT TO EXCEED 48" X 48"
- GRATE MUST BE INSTALLED IN A LEVEL BED RECESS
- RAILS ARE 6061-T6 ALUMINUM ALLOY; FRAMES ARE 6063-T6 ALUMINUM ALLOY
- TREAD RAILS MUST RUN PERPENDICULAR TO TRAFFIC DIRECTION
- DESIGN CLEARANCE BETWEEN GRATE AND FRAME IS 1/8"
- ACTUAL ACHIEVEABLE GRATE LENGTH IS DEPENDANT ON BOTH NUMBER AND SIZE OF SECTIONS
- SITE OPENING LENGTH MUST BE ADJUSTED TO GRATE AND FRAME ACHIEVEABLE LENGTH
- ADDITIONAL INFORMATION CAN BE FOUND IN THE PRODUCT SPECIFICATION AND IS CONSIDERED PART OF THIS TRANSMITTAL

PROJECT:

ARCHITECT:

CONTRACTOR:

RAIL:

**G-550R**

FRAME:

**G-550L**



TITLE: G-550 - 1" Rectangle Grid Foot Grille  
Mechanically Fastened Frame  
Rectangular Cut Grate

NAME	DATE	SIZE	DWG. NO.	REV
DRAWN	DKL	01/12/18	A	A
RELEASED	DT	01/12/18	WEIGHT:	SHEET 1 OF 1

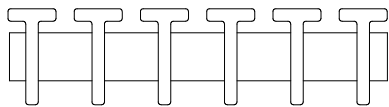

G-550R

QTY.	MODEL	WIDTH	LENGTH	LOCATION

RECESS OPENING DIMENSIONS:

120.000 WIDTH X 120.000 LENGTH

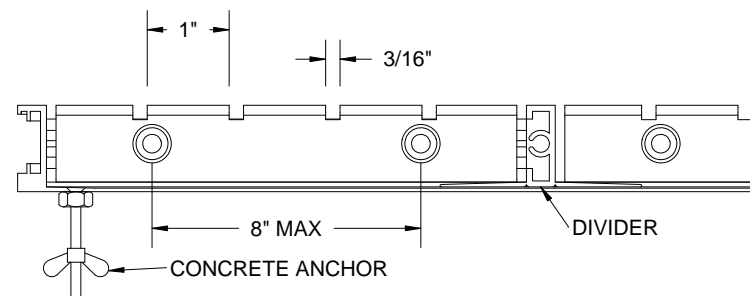
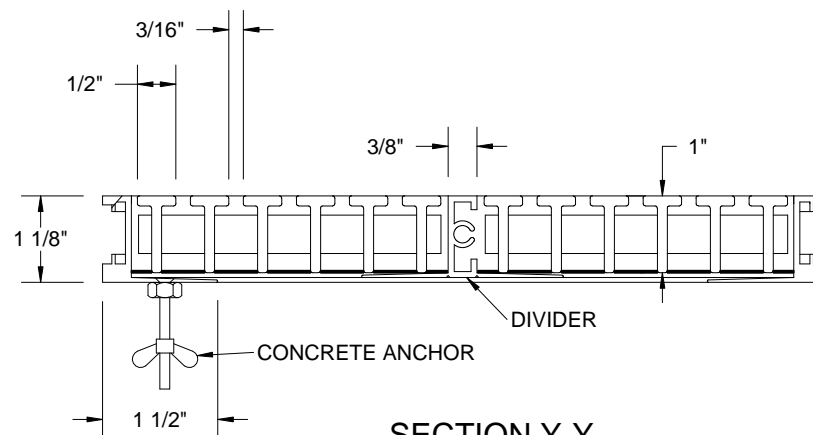
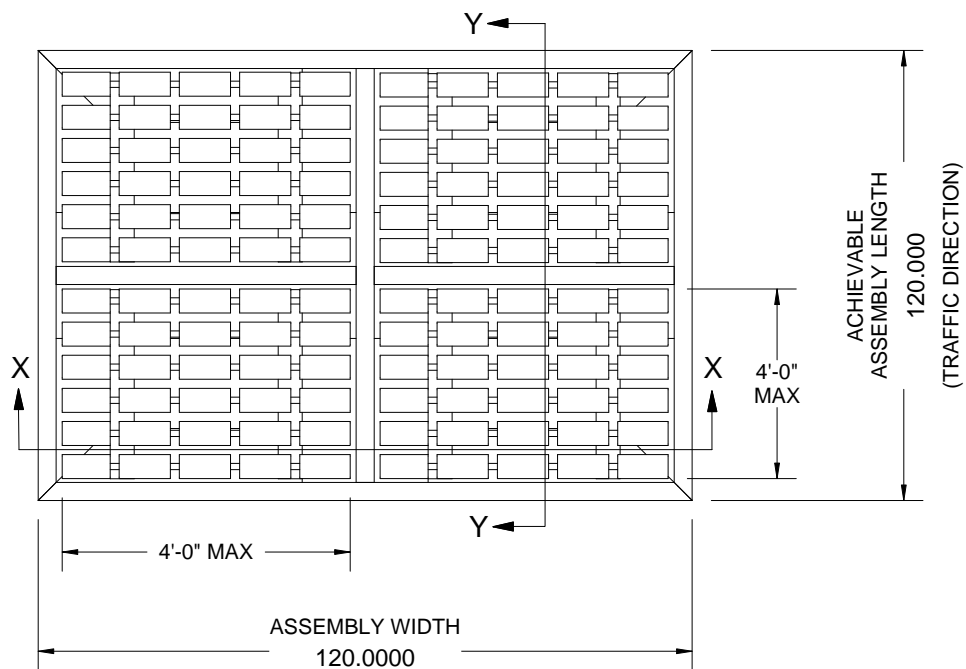

- NOTES:
- MAXIMUM GRATE SECTION SIZE NOT TO EXCEED 48" X 48"
  - GRATE MUST BE INSTALLED IN A LEVEL BED RECESS
  - RAILS ARE 6061-T6 ALUMINUM ALLOY; FRAMES ARE 6063-T6 ALUMINUM ALLOY
  - TREAD RAILS MUST RUN PERPENDICULAR TO TRAFFIC DIRECTION
  - DESIGN CLEARANCE BETWEEN GRATE AND FRAME IS 1/8"
  - ACTUAL ACHIEVEABLE GRATE LENGTH IS DEPENDANT ON BOTH NUMBER AND SIZE OF SECTIONS
  - SITE OPENING LENGTH MUST BE ADJUSTED TO GRATE AND FRAME ACHIEVEABLE LENGTH
  - ADDITIONAL INFORMATION CAN BE FOUND IN THE PRODUCT SPECIFICATION AND IS CONSIDERED PART OF THIS TRANSMITTAL

PROJECT:			
ARCHITECT:			
CONTRACTOR:			
RAIL:		<b>G-550R</b>	
FRAME:		<b>G-550C</b>	
		TITLE: G-550R - 1" Aluminum Foot Grille Cast In Frame Rectangular Cut Grate	
NAME	DATE	SIZE	DWG. NO.
DRAWN DKL	01/12/18	A	
RELEASED DT	01/12/18	WEIGHT:	
			REV
			SHEET 1 OF 1

PROPRIETARY AND CONFIDENTIAL: THE INFORMATION CONTAINED IN THIS DRAWING IS THE SOLE PROPERTY OF AMARCO PRODUCTS. ANY REPRODUCTION IN PART OR AS A WHOLE WITHOUT THE WRITTEN PERMISSION OF AMARCO PRODUCTS IS PROHIBITED.