

G-740 w/ Polypropylene Brush Insert

Frame Options:

1/8" GF-740L Mechanically fastened level-bed

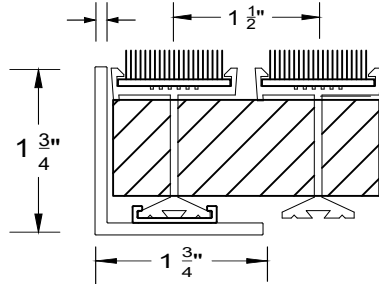

GF-740C Cast in level-bed

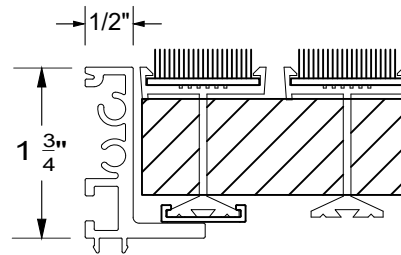

GF-740XD Cast-in extra deep-pit

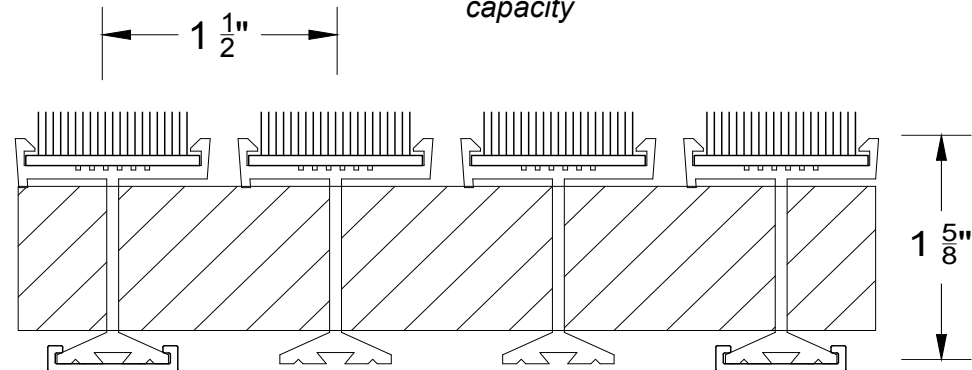
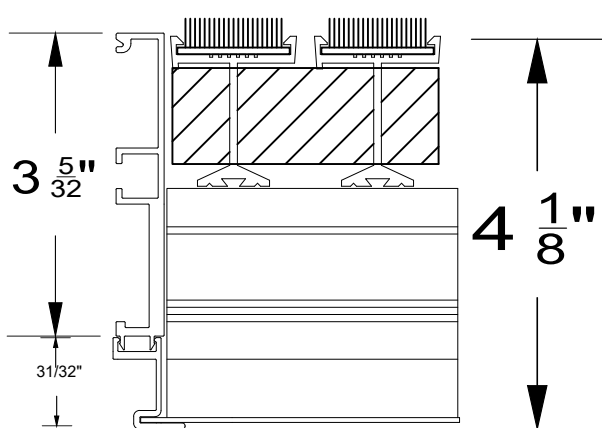

Features:

- 6063 T-5 extruded aluminum rails
- 1-5/8" high rails, making the grate ideal for trapping large amounts of snow, slush, dirt, and mud
- 3/16" gaps between rails for maximum drainage
- Durable polypropylene brush inserts, perfect for harsh elements
- 1" aluminum keylock every 6" for extra stability
- 400 lbs./wheel rolling load weight capacity

Finishes:

- Aluminum rails and frames available in mill (standard), clear anodized, dark bronze anodized, and black anodized
- Brush inserts: Gray, jet black, and brown (samples available on request)

Aluminum Keylock



Project:

Customer:

Architect:

G-740 Diamond Tread Vinyl Inserts

Frame Options:

GF-740L Mechanically fastened level-bed

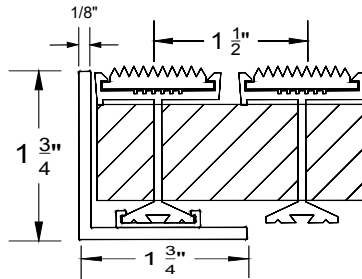

GF-740C Cast in level-bed

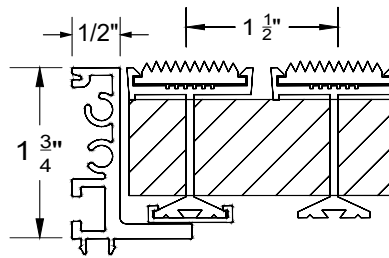

GF-740XD Cast-in extra deep pit

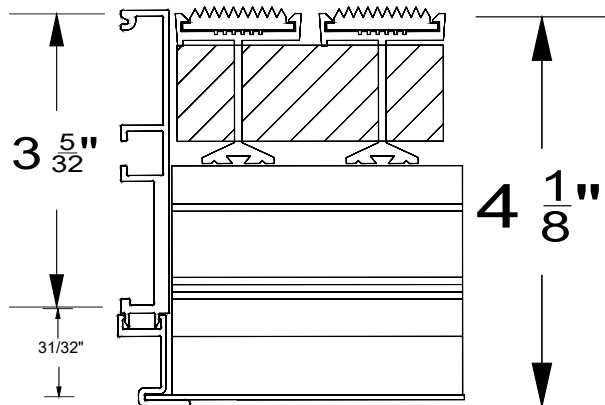

Features:

- 6063 T-5 extruded aluminum rails
- 1-5/8" high rails, making the grate ideal for trapping large amounts of snow, slush, dirt, and mud
- 3/16" gaps between rails for maximum drainage
- Diamond tread vinyl inserts, specifically designed for high-traffic applications
- 1" aluminum keylock every 6" for extra stability
- 400 lbs./wheel rolling load weight capacity

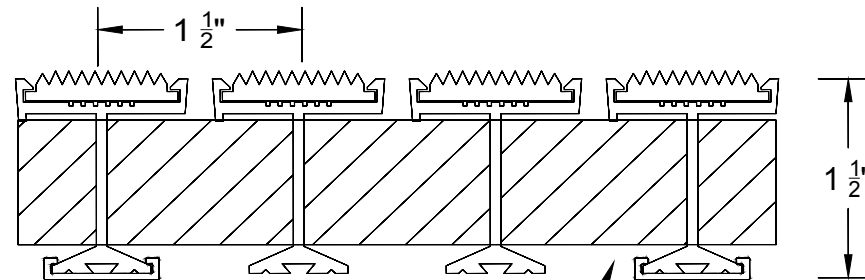

Aluminum
Keylock

Finishes:

- Aluminum rails and frames available in mill (standard), clear anodized, dark bronze anodized, and black anodized
- Vinyl inserts: Gray, black, blue, beige, and brown (samples available on request)



info@amarcomats.com | (866) 688-6287

Project:

Customer:

Architect:

G-740 w/ Nylon Carpet Insert

Frame Options:

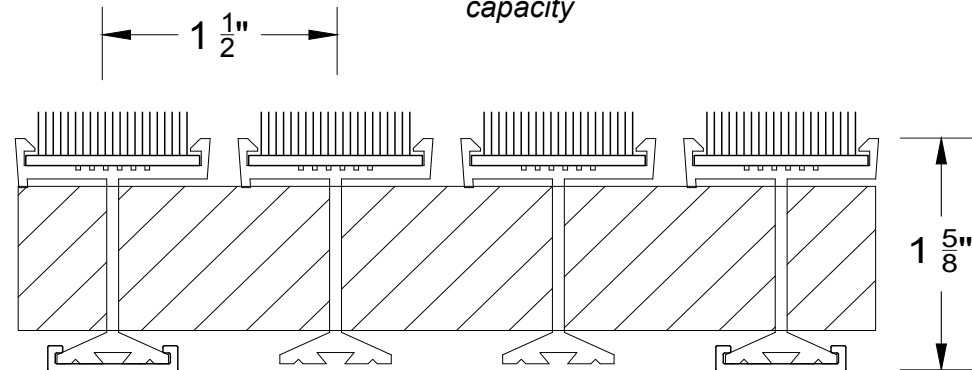
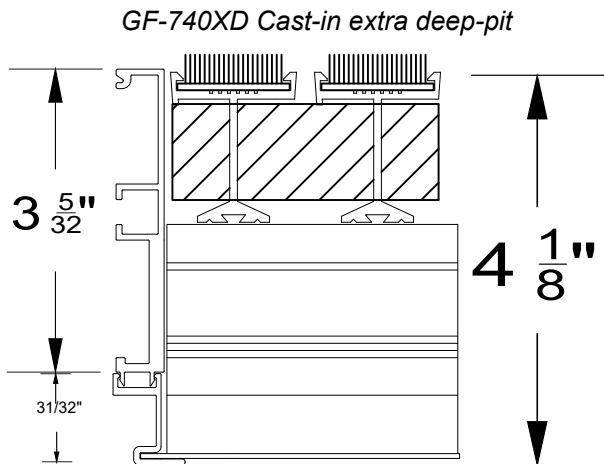
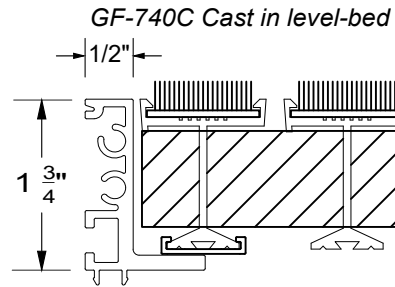
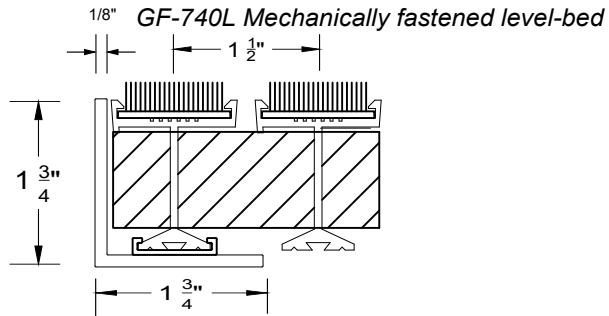

Features:

- 6063 T-5 extruded aluminum rails
- 1-5/8" high rails, making the grate ideal for trapping large amounts of snow, slush, dirt, and mud
- 3/16" gaps between rails for maximum drainage
- Durable polypropylene brush inserts, perfect for harsh elements
- 1" aluminum keylock every 6" for extra stability
- 400 lbs./wheel rolling load weight capacity

Finishes:

- Aluminum rails and frames available in mill (standard), clear anodized, dark bronze anodized, and black anodized
- Brush inserts: Gray, jet black, and brown (samples available on request)

Aluminum Keylock



Project:

Customer:

Architect:

G-740 w/ Serrated Aluminum Inserts

Frame Options:

GF-740L Mechanically fastened level-bed

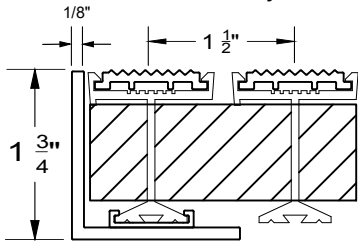

GF-740C Cast-in level-bed

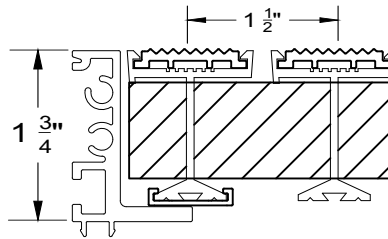

GF-740XD Cast-in extra deep-pit

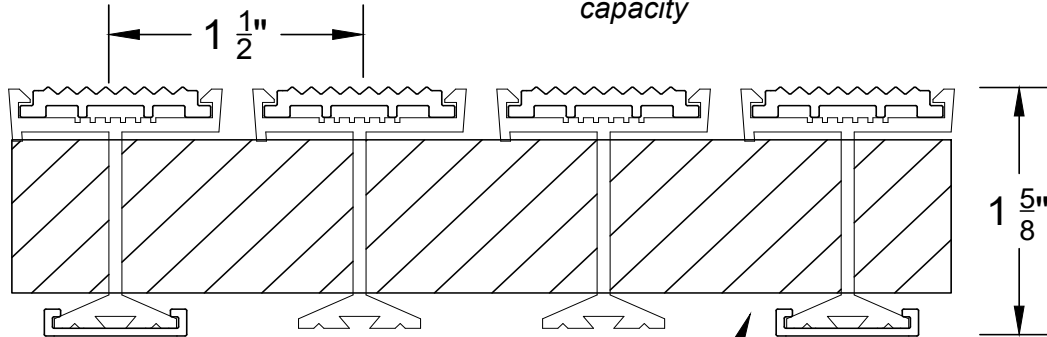
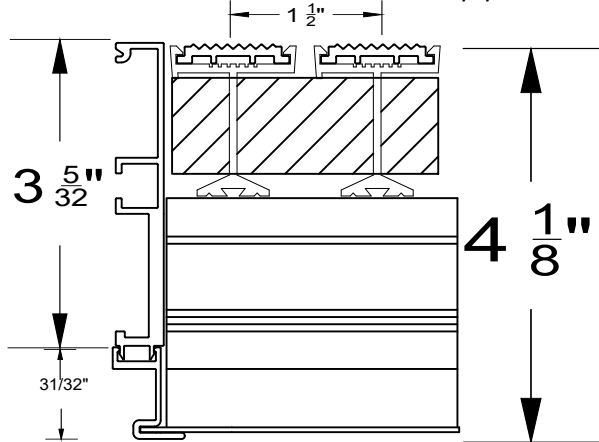

Features:

- 6063 T-5 extruded aluminum rails
- 1-5/8" high rails, making the grate ideal for trapping large amounts of snow, slush, dirt, and mud
- Serrated aluminum inserts, ideal for removing caked-on mud and grime from foot traffic
- $\frac{3}{16}$ " gaps between rails for maximum drainage
- 1" aluminum keylock every 6" for extra stability
- 400 lbs./wheel rolling load weight capacity

Finishes:

- Aluminum rails and frames available in mill (standard), clear anodized, dark bronze anodized, and black anodized
- Serrated aluminum inserts available in mill, clear anodized, dark bronze anodized, and black anodized

Aluminum
Keylock



info@amarcomats.com | (866) 688-6287

Project:

Customer:

Architect: